

SPECIFICATIONS

ELECTRICAL

FREQUENCY RANGE \_\_\_\_\_ DC - 67 GHz  
 VSWR  
 DC - 67 GHz \_\_\_\_\_ 1.35:1 MAX  
 POWER (AVG. MAX.) \_\_\_\_\_ 20 Watts @25°C  
 IMPEDANCE \_\_\_\_\_ 50 OHMS  
 RF LEAKAGE \_\_\_\_\_ >90 dBc  
 OPERATING TEMP. RANGE \_\_\_\_\_ -55 - 125°C  
 PHASE MATCHING \_\_\_\_\_ ±10°(TO P/N's 6782-0000-00  
 AND 6781-0000-00)

MATERIAL AND FINISH:

HOUSING, COUPLING NUT \_\_\_\_\_ GOLD PLATED  
 STAINLESS STEEL  
 CONTACT \_\_\_\_\_ GOLD PLATED  
 BERYLLIUM COPPER  
 DIELECTRIC \_\_\_\_\_ PTFE

MARKING

PART LOOKS LIKE PRODUCT IMAGE ABOVE.  
 PART MARKING ORIENTATION AND FORMAT AS SHOWN.  
 MARKING TO BE AS LARGE AS POSSIBLE, CLEAR, READABLE.  
 YYWW EQUALS DATE CODE.

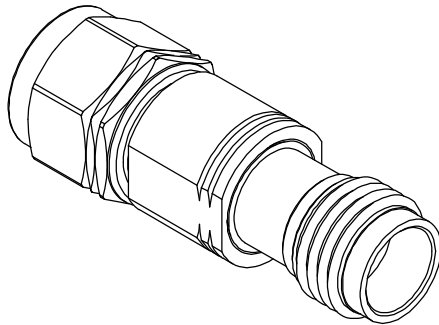

REVISIONS				
REV	DESCRIPTION	ECO #	DATE	APPROVED
-	INITIAL RELEASE	18-157	10/15/18	T.KUHN

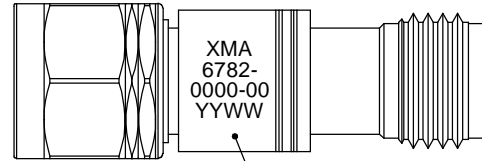
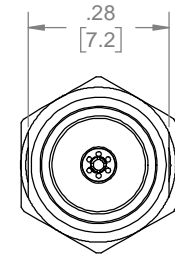
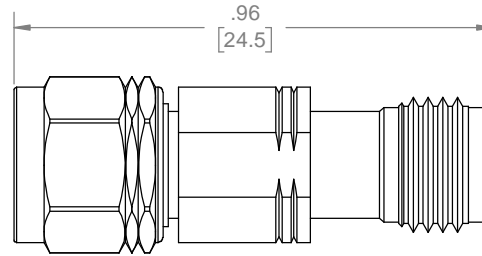

MARKING AREA

QTY.	PART NUMBER	DESCRIPTION	ITEM NO.
X	6782-0000-00	ADAPTER, 1.85mm-m/f, DC-67 GHz, 20W	
1	TA-6782-0000-00U	ASSY, ADAPTER, 1.85mm-m/f, DC-67 GHz, 20W, UNMARKED	1

DRAWING PRACTICES PER ANSI-Y-14.5 MIL-STD-100 & 1000	
DIMENSIONS ARE IN INCHES AND APPLY BEFORE / AFTER PROCESSING	
SURFACE ROUGHNESS μINCHES	63
FINISH:	
SEE NOTES	
MATERIAL:	
SEE NOTES	
NOTE: THIS DRAWING INCORPORATES THIRD ANGLE PROJECTION.	
INTERPRET IAW ANSI Y14.5-1982	

UNLESS OTHERWISE SPECIFIED TOLERANCES IN:	
DECIMALS	INCH [MM]
.X"	.05" [1.27]
.XX"	.03" [.76]
.XXX"	.010" [.25]
ANGLES ±0°30'	
REMOVE ALL BURRS/SHARP W/ BREAK / R OF .003" TO .0005" UNLESS OTHERWISE NOTED DIAS CONCENTRIC <.003 T.I.R.	
DO NOT SCALE PRINT	

DRAWN	DATE
MCCORMICK	4/13/15
CHECKED	DATE
MCCORMICK	4/13/15
ENG. APPR.	DATE
T.KUHN	4/13/15

Phone: 603-222-2256 Fax: 603-222-2259  
 150 Dow Street, Manchester, NH 03101

TITLE

**ADAPTER, 1.85mm-m/f, DC-67GHz, 20W**

SIZE	CAGE CODE	DRAWING NUMBER	REV
B	3HT76	6782-0000-00	-
SCALE	PLATED AREA SQ. IN	SHEET 1 OF 1	

THESE DRAWINGS AND SPECIFICATIONS ARE THE PROPERTY OF XMA CORP. OR OMNI SPECTRA AND SHALL NOT BE REPRODUCED, COPIED NOR USED - IN WHOLE OR IN PART - AS A BASIS FOR THE MANUFACTURE OR SALE OF OTHER ITEMS WITHOUT THE EXPRESS WRITTEN PERMISSION OF XMA CORP.