

SPECIFICATIONS

ELECTRICAL

FREQUENCY _____ DC-40 GHz
 ATTENUATION ACCURACY _____ ±0.75 dB GOAL
 0, 3, 6, 10, 20 & 30dB _____
 VSWR _____ 1.40:1 GOAL
 POWER _____ 1W
 OPERATING TEMPERATURE RANGE _____ 4 KELVIN TO +125°C

MECHANICAL

HOUSING _____ C101 COPPER, GOLD PLATED
 WITH WHITE BRONZE UNDERPLATE
 (NO NICKEL)
 CONTACT _____ BERYLLIUM COPPER, GOLD PLATED
 IAW MIL-PRF-39012
 TORQUE _____ 7-10 in/lbs
 RoHS COMPLIANT DEVICE

MARKING:

PART LOOKS LIKE PRODUCT IMAGE ABOVE.
 PART MARKING ORIENTATION AND FORMAT AS SHOWN.
 REPLACE XX WITH APPROPRIATE SINGLE OR DOUBLE DIGIT dB VALUE.
 MARKING TO BE AS LARGE AS POSSIBLE, CLEAR, READABLE.
 YYWW EQUALS DATE CODE.

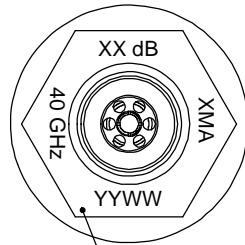

MARKING AREA

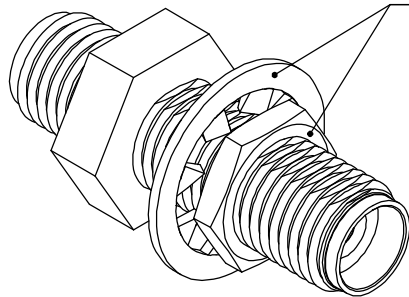

HARDWARE SHALL BE PACKAGED SEPARATELY IN THEIR OWN BAGS.

REVISIONS

REV	DESCRIPTION	ECO #	DATE	APPROVED
A	ADDED WASHER AND NUT	19-104	9/18/19	T.KUHN
B	REVISED WASHER AND NUT	20-155	10/5/20	MES
C	CORRECTED GHZ IN BOM	20-174	10/19/20	DP
D	ADDED NUT & WASHER PKG NOTE	20-052	4/13/21	CM

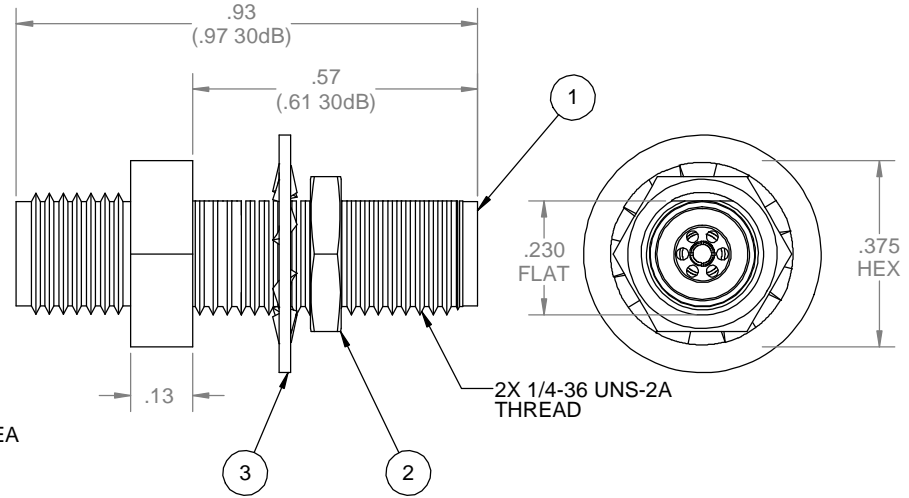

QTY.	PART NUMBER	DESCRIPTION	ITEM NO.
X	4880-5522-dB-CRYO	ATTENUATOR, 2.92mm-f, DC-40 GHz, 1W	
1	TA-4880-5522-dBU-CRYO	ASSY, ATTENUATOR, 2.92mm-f, DC-40 GHz, 1W, UNMARKED	1
1	5002-14-0153	JAM NUT	2
1	5040-28-0153	INTERNAL TOOTH LOCK WASHER	3

DRAWING PRACTICES PER ANSI-Y-14.5 MIL-STD-100 & 1000
 DIMENSIONS ARE IN INCHES AND APPLY BEFORE / AFTER PROCESSING
 SURFACE ROUGHNESS μ INCHES 63
 FINISH:
 SEE NOTES
 MATERIAL:
 SEE NOTES
 NOTE:
 THIS DRAWING INCORPORATES THIRD ANGLE PROJECTION.
 INTERPRET IAW ANSI Y14.5-1982

UNLESS OTHERWISE SPECIFIED TOLERANCES IN:
 DECIMALS INCH [MM]
 .X" .05" [1.27]
 .XX" .03" [.76]
 .XXX" .010" [.25]
 ANGLES ±0°30'
 REMOVE ALL BURRS/SHARP W/ BREAK / R OF .003" TO .0005" UNLESS OTHERWISE NOTED
 DIAS CONCENTRIC <.003 T.I.R.

DO NOT SCALE PRINT

DRAWN DATE
 MCCORMICK 7/5/18
 CHECKED DATE
 MCCORMICK 7/5/18
 ENG. APPR. DATE
 T.KUHN 7/5/18

THESE DRAWINGS AND SPECIFICATIONS ARE THE PROPERTY OF XMA CORP. OR OMNI SPECTRA AND SHALL NOT BE REPRODUCED, COPIED NOR USED - IN WHOLE OR IN PART - AS A BASIS FOR THE MANUFACTURE OR SALE OF OTHER ITEMS WITHOUT THE EXPRESS WRITTEN PERMISSION OF XMA CORP.



Phone: 603-222-2256 Fax: 603-222-2259
 7 Perimeter Road, Manchester, NH 03103
 TITLE

ATTENUATOR, 2.92mm-f, DC-40GHz, 1W

SIZE	CAGE CODE	DRAWING NUMBER	REV
B	3HT76	4880-5522-dB-CRYO	D
SCALE	PLATED AREA SQ. IN	SHEET 1 OF 1	