

SPECIFICATIONS

ELECTRICAL:

FREQUENCY RANGE \_\_\_\_\_ 10 MHz - 40 GHz  
 IMPEDANCE \_\_\_\_\_ 50 OHMS  
 INSERTION LOSS \_\_\_\_\_ 0.75 dB MAX.  
 VSWR \_\_\_\_\_ 1.45:1 MAX.  
 VOLTAGE RATING \_\_\_\_\_ 200 VOLTS MAX. (INNER ONLY)  
 OPERATING TEMP \_\_\_\_\_ -65°C TO 125°C

MECHANICAL

CONNECTOR BODY AND COUPLING NUT \_\_\_\_\_ STAINLESS STEEL IAW A582, TYPE 303, PASSIVATED PER QQ-P-35  
 CONTACTS \_\_\_\_\_ GOLD PLATED BERYLLIUM COPPER  
 DIELECTRIC \_\_\_\_\_ HIGH TEMPERATURE PLASTIC BEAD

CONNECTOR INTERFACES, FINISHES AND MATERIALS COMPLY WITH BOTH MIL-PRF-39012 AND MIL-STD-348 FOR 2.92 mm (SMK) CONNECTORS AND INTERFACES AND MATE WITH SMA AND 3.5 mm CONNECTORS.

MARKING

PART LOOKS LIKE PRODUCT IMAGE ABOVE.  
 PART MARKING ORIENTATION AND FORMAT AS SHOWN.  
 MARKING TO BE AS LARGE AS POSSIBLE, CLEAR, AND READABLE.  
 YYWW EQUALS DATE CODE.

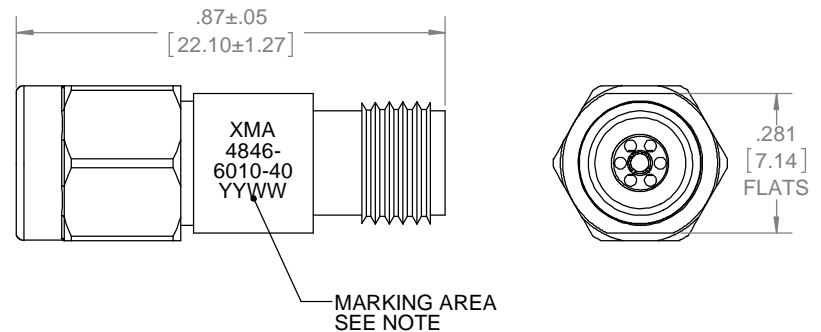
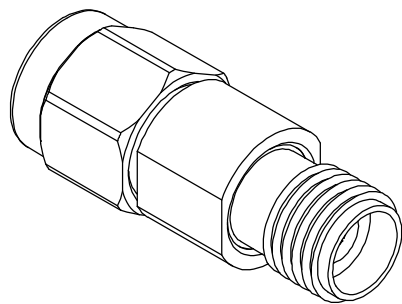

MARKING AREA  
 SEE NOTE

REVISIONS				
REV	DESCRIPTION	ECO #	DATE	APPROVED
A	ADDED MARKING	14-273	8/27/14	T.KUHN
B	UPDATE SPECS FORMAT	15-053	3/4/15	T.KUHN

QTY.	PART NUMBER	DESCRIPTION	ITEM NO.
X	4846-6010-40	DC BLOCK, 2.9mm-m/f, 10MHz - 40GHz	
1	TA-4846-6010-40U	ASSY, DC BLOCK, 2.9mm-m/f, 10MHz - 40GHz, UNMARKED	1

DRAWING PRACTICES PER ANSI-Y-14.5 MIL-STD-100 & 1000	
DIMENSIONS ARE IN INCHES AND APPLY BEFORE / AFTER PROCESSING	
SURFACE ROUGHNESS μINCHES	63
FINISH:	
MATERIAL:	
NOTE: THIS DRAWING INCORPORATES THIRD ANGLE PROJECTION.	
INTERPRET IAW ANSI Y14.5-1982	

UNLESS OTHERWISE SPECIFIED TOLERANCES IN:		
DECIMALS	INCH	(MM)
.X"	.05"	[1.27]
.XX"	.03"	[.76]
.XXX"	.010"	[.25]
ANGLES ±0°30'		
REMOVE ALL BURRS/SHARP W/ BREAK / R OF .003" TO .0005" UNLESS OTHERWISE NOTED		
DIAS CONCENTRIC <.003 T.I.R.		
DO NOT SCALE PRINT		

DRAWN	DATE
MCCORMICK	7/23/14
CHECKED	DATE
MCCORMICK	7/23/14
ENG. APPR.	DATE
T.KUHN	7/23/14

Phone: 603-222-2256 Fax: 603-222-2259  
 150 Dow Street, Manchester, NH 03101

TITLE  
**DC BLOCK, 2.9mm-m/f, 10MHz - 40GHz**

SIZE	CAGE CODE	DRAWING NUMBER	REV
B	3HT76	4846-6010-40	B
SCALE	PLATED AREA SQ. IN	SHEET 1 OF 1	

THESE DRAWINGS AND SPECIFICATIONS ARE THE PROPERTY OF XMA CORP. OR OMNI SPECTRA AND SHALL NOT BE REPRODUCED, COPIED NOR USED - IN WHOLE OR IN PART - AS A BASIS FOR THE MANUFACTURE OR SALE OF OTHER ITEMS WITHOUT THE EXPRESS WRITTEN PERMISSION OF XMA CORP.