

5

4

3

2

1

SPECIFICATIONS

ELECTRICAL

FREQUENCY _____ DC-18GHz

VSWR
 DC - 12.4GHz _____ 1.15:1 MAX
 12.4 - 18GHz _____ 1.20:1 MAX

INPUT POWER _____ 2 WATTS AVG.
 POWER DERATES LINEARLY TO 1 WATT @ 125°C

PEAK POWER _____ 500 WATTS
 (5u Sec PULSE, .05% DUTY CYCLE)

IMPEDANCE _____ 50 OHMS

OPERATING TEMP RANGE _____ -65°C TO +125°C

MECHANICAL

TYPE N CONNECTOR _____ PASSIVATED STAINLESS STEEL

CONDUCTORS _____ GOLD PLATED BERYLLIUM
 _____ COPPER

PLUG CAP _____ NI PLATED BRASS

DIELECTRIC _____ TEFLON

MARKING

PART LOOKS LIKE PRODUCT IMAGE ABOVE.
 PART MARKING ORIENTATION AND FORMAT AS SHOWN.
 MARKING TO BE AS LARGE AS POSSIBLE BE, CLEAR, READABLE.
 YYWW EQUALS DATE CODE.

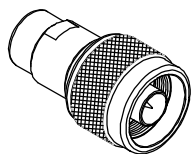

REVISIONS				
REV	DESCRIPTION	ECO #	DATE	APPROVED
-	INITIAL RELEASE	15-040	2/18/15	T.KUHN

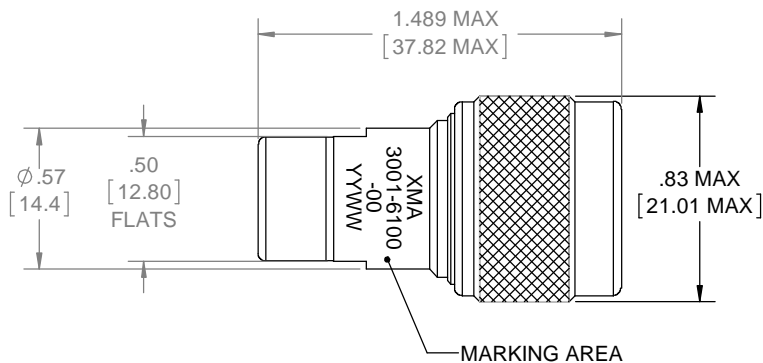

QTY.	PART NUMBER	DESCRIPTION	ITEM NO.
X	3001-6100-00	TERMINATION, N-m, DC-18 GHz, 2W	
1	TA-3001-6000-02-DFU	ASSEMBLY, TERMINATION, N-m, DC-18 GHz, 2W, UNMARKED	1

DRAWING PRACTICES PER ANSI-Y-14.5 MIL-STD-100 & 1000	
DIMENSIONS ARE IN INCHES AND APPLY BEFORE / AFTER PROCESSING	
SURFACE ROUGHNESS μ INCHES	63
FINISH:	
MATERIAL:	
NOTE: THIS DRAWING INCORPORATES THIRD ANGLE PROJECTION.	
	INTERPRET IAW ANSI Y14.5-1982

UNLESS OTHERWISE SPECIFIED TOLERANCES IN:	
DECIMALS	INCH (MM)
.X"	.05" [1.27]
.XX"	.03" [.76]
.XXX"	.010" [.25]
ANGLES $\pm 0^{\circ}30'$	
REMOVE ALL BURRS/SHARP W/ BREAK / R OF .003" TO .0005" UNLESS OTHERWISE NOTED DIAS CONCENTRIC <.003 T.I.R.	
DO NOT SCALE PRINT	

DRAWN	DATE
MCCORMICK	2/18/15
CHECKED	DATE
MCCORMICK	2/18/15
ENG. APPR.	DATE
T.KUHN	2/18/15

Phone: 603-222-2256 Fax: 603-222-2259
 150 Dow Street, Manchester, NH 03101

TITLE

TERMINATION, DC-18GHz, 2 W

SIZE	CAGE CODE	DRAWING NUMBER	REV
B	3HT76	3001-6100-00	-
SCALE	PLATED AREA SQ. IN	SHEET 1 OF 1	

5

4

3

2

1